



EVOMAQ[®]
EQUIPAMENTOS

CATALOG **P80/20**



**CONSTANT
EVOLUTION**

CONTINUOUS FLIGHT AUGER DRILL (CFA DRILL) EVOMAQ®

P80/20

SPECIAL FEATURES

- HIGH TORQUE OF 10,000 KGF.M
- LINDE HYDRAULIC PUMP WITH CLOSED CIRCUIT
- POWERFUL MWM ENGINE WITH 330 hp
- DIAMETER UP TO 800 mm
- DRILLING HEAD WITH MOTORS AND HYDRAULIC REDUCERS
- LARGER AND ROBUST CONVEYORS
- EXCLUSIVE HYDRAULIC VISE FOR ALL DIAMETERS



COMPONENTS

- AIR-CONDITIONED CABIN
- CONTROL PANEL
- MONITORING COMPUTER
- HYDRAULIC TOWER ADJUSTMENTS
- TURRET FOOT
- HYDRAULIC LEVELING LEGS
- AUGER RACK
- WASH PUMP



SPECIAL FEATURES

WWW.EVOMAQ.COM.BR



HIGH TORQUE OF 10.000 KGF.M

In this equipment model, we adapted a large machine into a small one! The EVOMAQ P80/20 has a high torque compared to a large machine. This characteristic provides a significant advantage, enhancing both daily production rates and the equipment's durability when encountering tough, resistant soil layers.



LINDE HYDRAULIC PUMP WITH CLOSED CIRCUIT

The EVOMAQ P80/20 has the same hydraulic system used in the most efficient large machines around the world. This is possible due to a LINDE hydraulic piston pump with a closed circuit that is used exclusively to supply the drilling command. Contact our team and know more about this feature.



POWERFUL MWM ENGINE WITH 330 HP

A high-performance hydraulic system like this needs to be aligned with a high installed diesel power and that is why the P 80/20 is equipped with the MWM 6-cylinder intercooled turbo diesel engine that has 330 hp providing strength, performance and clearance, to prevent it from operating at its maximum capacity.

SPECIAL FEATURES

WWW.EVOMAQ.COM.BR



DIAMETER UP TO 800 MM

As previously mentioned, the EVOMAQ P80/20 is a large machine with the characteristics of a small one and proves this not only in relation to its high torque but also in its capacity for drilling up to 800 mm in diameter, providing much more autonomy for the execution of your projects. All these advantages in a machine with a total weight of 21 tons.

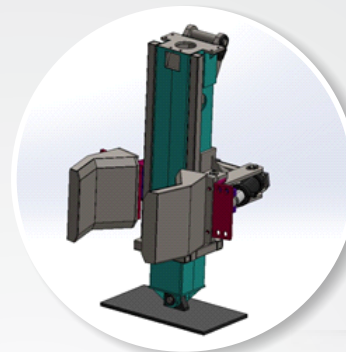

EXCLUSIVE HYDRAULIC VICE FOR ALL DIAMETERS

To keep the auger alignment during the drilling, the drill of EVOMAQ® has an exclusive hydraulic vise system for all diameters, facilitating and ensuring enhanced safety for individuals involved in the operation.

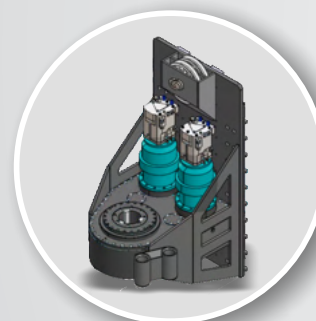

DRILLING HEAD WITH MOTORS AND HYDRAULIC REDUCERS

Designed to operate with two hydraulic motors and featuring an innovative dual reducer design, this head delivers an impressive maximum torque of 10.000 kgf.m, maintaining its compact characteristic. This not only minimizes component wear, but also substantially increases production for our customers.



LARGER AND ROBUST CONVEYORS

As it is equipment with a capacity of up to 800 mm in diameter, we redoubled our attention to the stability of equipment on site. Therefore, this equipment features conveyors that have been upgraded from 500 mm to 600 mm in width and from 3,500 mm to 4,450 mm in length. Its reducers and guide wheels have also been increased, generating even more stability and driving force on the most different types of soil.

COMPONENTS

WWW.EVOMAQ.COM.BR



AIR-CONDITIONED CABIN

Consistently paying attention to our customers' feedback, we've introduced a custom-designed cabin exclusively tailored for our continuous flight auger (CFA). This cabin not only enhances comfort and safety but also harmonizes seamlessly with the overall design, elevating the aesthetics and overall value of our drill rigs.

CONTROL PANEL



With an easy-to-operate, intuitive and strategically located instrument panel, the operator has complete control over the equipment.

MONITORING COMPUTER



The EVOMAQ® Continuous Flight Auger Drill (CFA) has a high-tech monitoring computer that generates accurate, real-time data on drilling and concreting, through detailed graphics, providing reliability for the customer.

HYDRAULIC TOWER ADJUSTMENTS

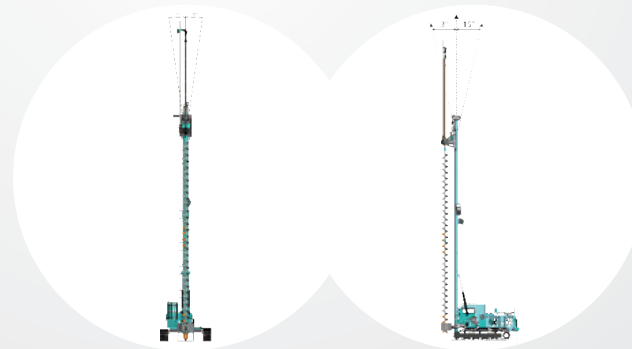

TOWER SIDE SLOPE

TOWER ELEVATION

In addition to greater agility, the hydraulic adjustments of the tower are essential for the safe displacement of the EVOMAQ drill rig on construction site. When in movement, the tower can be tilted sideways and backwards, maintaining the center of gravity and providing even more safety for the operation.

COMPONENTS

WWW.EVOMAQ.COM.BR



TURRET FOOT

In order to provide greater stability and safety when executing the pile, the turret foot has large dimensions, ensuring higher machine stability and precision when the auger is removed.



HYDRAULIC LEVELING LEGS

Equipped with hydraulic leveling legs, the P80/20 CFA drill of EVOMAQ® keeps the equipment level and the pile in the plumb line, allowing for better quality and safety in the execution of the piles.



AUGER RACK

A robust and reinforced racking system with ratchets and steel cable latches, which guarantees greater transport security during assembly and handling.



HIGH PRESSURE WASHER PUMP

Maintaining cleanliness in your equipment is the initial step toward optimal performance and long-lasting durability. That's why the EVOMAQ continuous flight auger (CFA) includes a high-pressure water pump, simplifying the process of equipment cleaning and maintenance.

TECHNICAL SPECIFICATIONS

Minimum drilling diameter	300 mm
Maximum drilling diameter	800 mm
Maximum drilling depth	20m (14 + 6)
First gear rotation	09 RPM
Second gear rotation	14 RPM
Third gear rotation	20 RPM
Fourth gear rotation	29 RPM
Drilling torque	13.000 kgf.m
Extraction force	45.000 kfg
Overall equipment width (transport)	2530mm
Overall equipment width (operational)	3722mm
Total track shoe width	600mm
Track length	4450mm
Maximum transfer speed	2km/h
Total equipment weight (transport)	21 Ton
Engine power	330cv
Total Height (Work)	23047mm
Total Height (Transport)	2750mm
Total Length (Work)	5811mm
Total Length (Transport)	9500mm

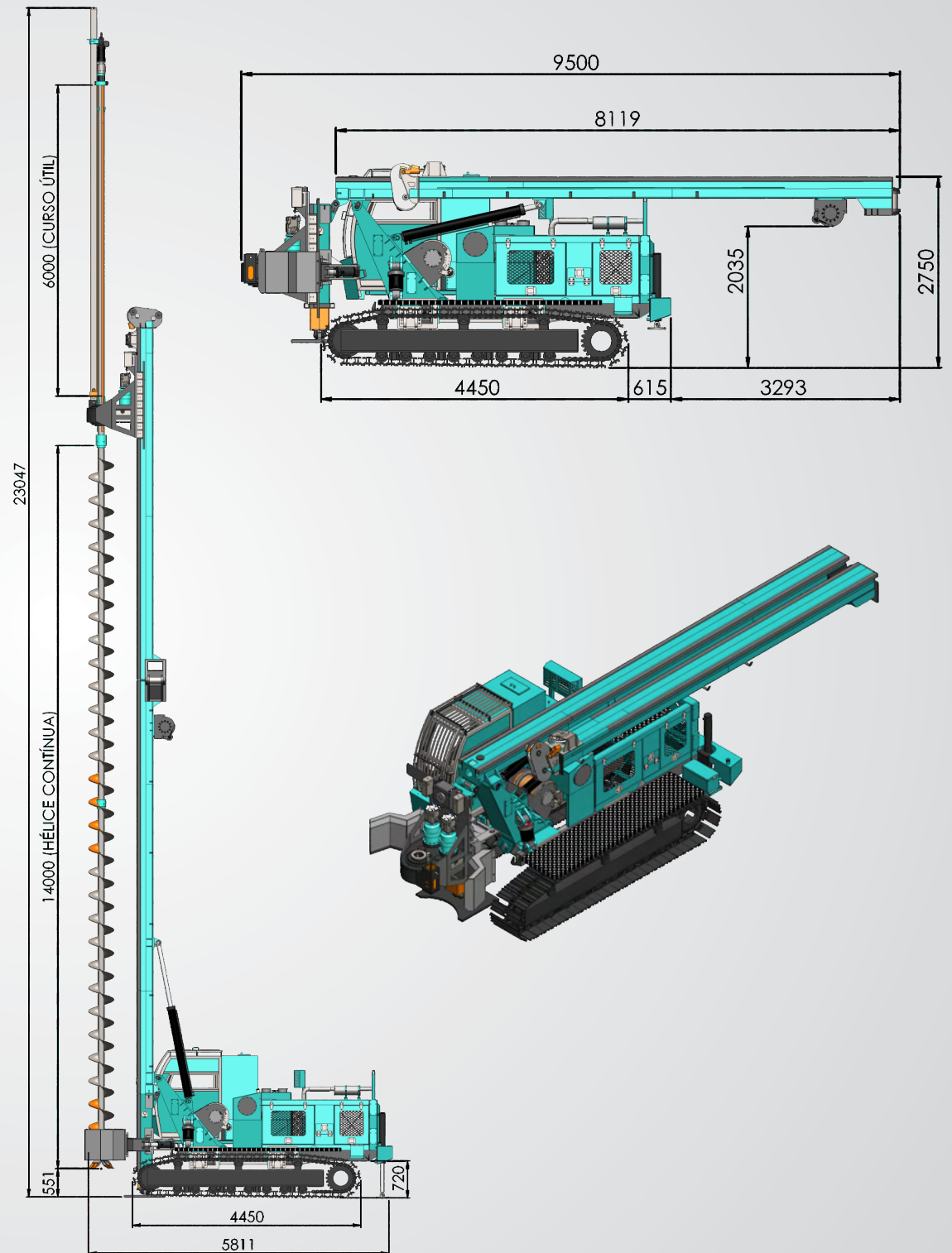



EVOMAQ[®]
EQUIPAMENTOS

MOGI MIRIM/SP
TEL.: (+55) 19 3806.1478 | 19 97158.9961
E-MAIL: VENDAS@EVOMAQ.COM.BR

WWW.EVOMAQ.COM.BR



EXPLORE OUR LINE OF CONCRETE PUMPS FOR ADDITIONAL INSIGHTS



CONCRETE
AUTO PUMP
EVOMAQ[®]



BETON
CONCRETE PUMP
EVOMAQ[®]



CRAWLER
PUMP
EVOMAQ[®]



STATIONARY
CONCRETE PUMP
EVOMAQ[®]