



EVOMAQ[®]
EQUIPAMENTOS

CATÁLOGO
ESTACA ESCAVADA
SOBRE CAMINHÃO
P100/15 | P140/20



ESTACA ESCAVADA SOBRE CAMINHÃO EVOMAQ

MOVIDOS PELA EVOLUÇÃO

Projetada para diâmetros de até 1,40 metros e para profundidades de até 20 metros, a estaca escavada sobre caminhão é ideal para projetos, onde não ocorram presença do nível do lençol freático.

As perfuratrizes de estaca escavada sobre caminhão EVOMAQ® P100/15 e P140/20 possuem uma torre compacta de baixa altura que permite a utilização do equipamento dentro de galpões e edificações com pé direito restrito.

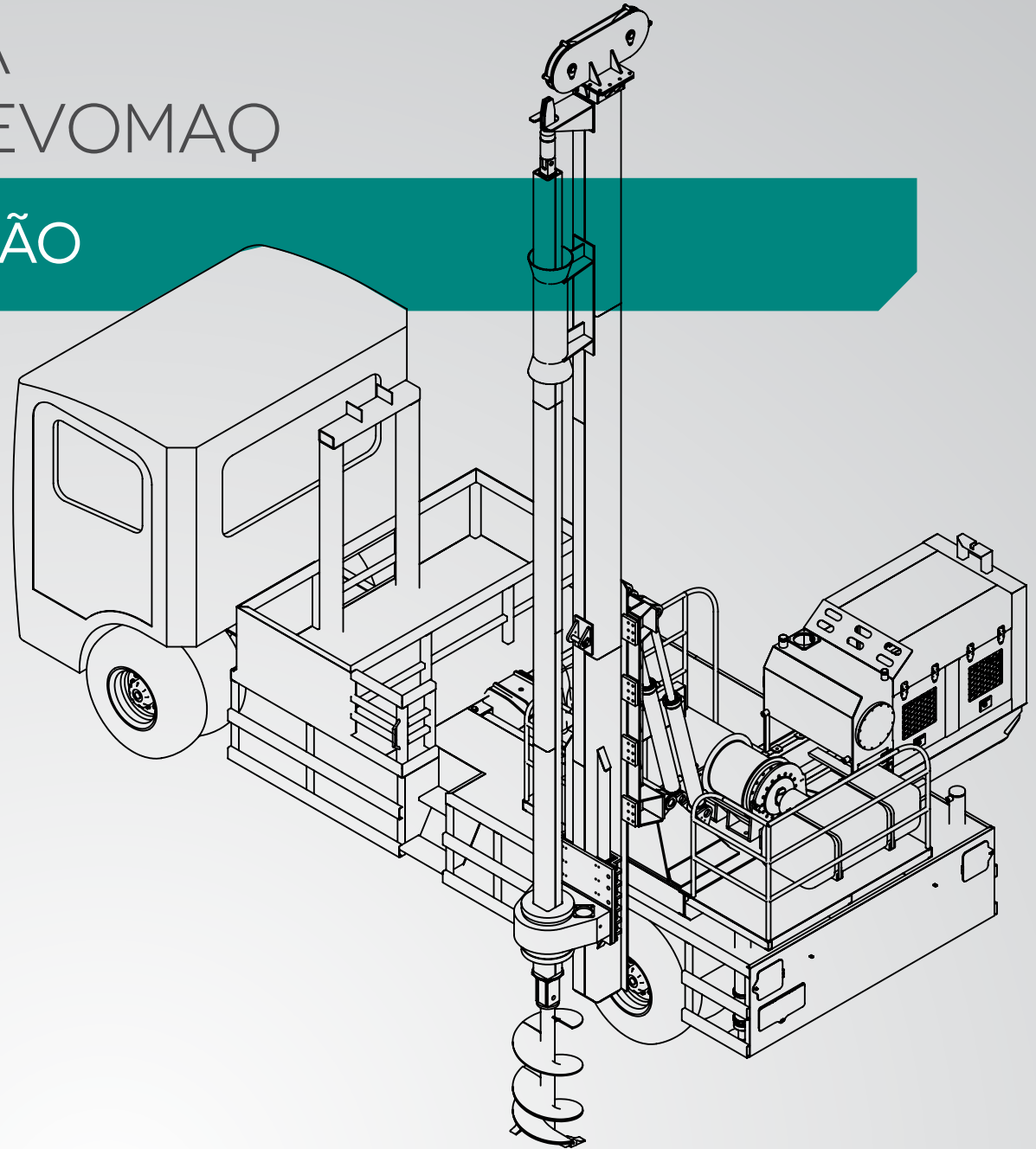

DIFERENCIAIS

- POTENTE MOTOR MWM
- TORRE DE BAIXA ALTURA
- ALTO TORQUE
- FACILIDADE NO TRANSPORTE



ESPECIFICAÇÕES TÉCNICAS

| | P100/15 | P140/20 |
|--|------------------|--------------------|
| Largura total do equipamento | 2530mm | 2530mm |
| Comprimento total do equipamento | 8450mm | 8450mm |
| Comprimento total do equipamento para trabalho | 9300mm | 9300mm |
| Diâmetro mínimo de perfuração | 250mm | 250mm |
| Diâmetro máximo de perfuração | 1000mm | 1400mm |
| Profundidade máxima de perfuração | 15m | 20m |
| Rotação máxima do cabeçote | 57 RPM | 50 RPM |
| Torque máximo | 1.500 kgf.m | 3.000 kgf.m |
| Força de extração | 6.000 kgf.m | 6.000 kgf.m |
| Motor e potência | MWM 229-4NA 83cv | MWM 4.12 TCA 152cv |
| Peso total do equipamento | 10.230 kg | 10.230 kg |
| Peso total do conjunto (equipamento/caminhão) | 15.000 kg | 15.560 kg |

DIMENSÕES: TRABALHO

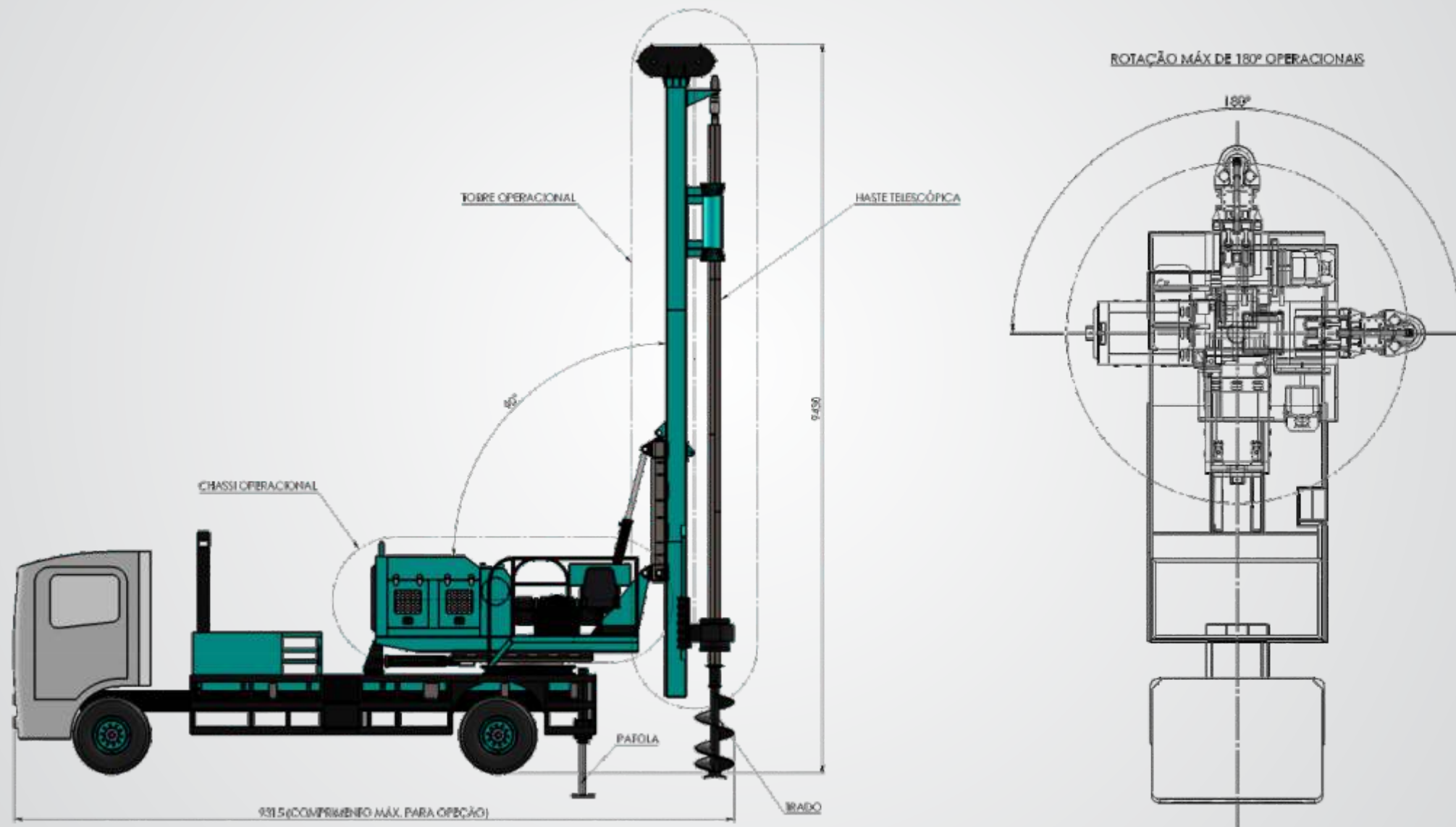

DIMENSÕES: TRANSPORTE

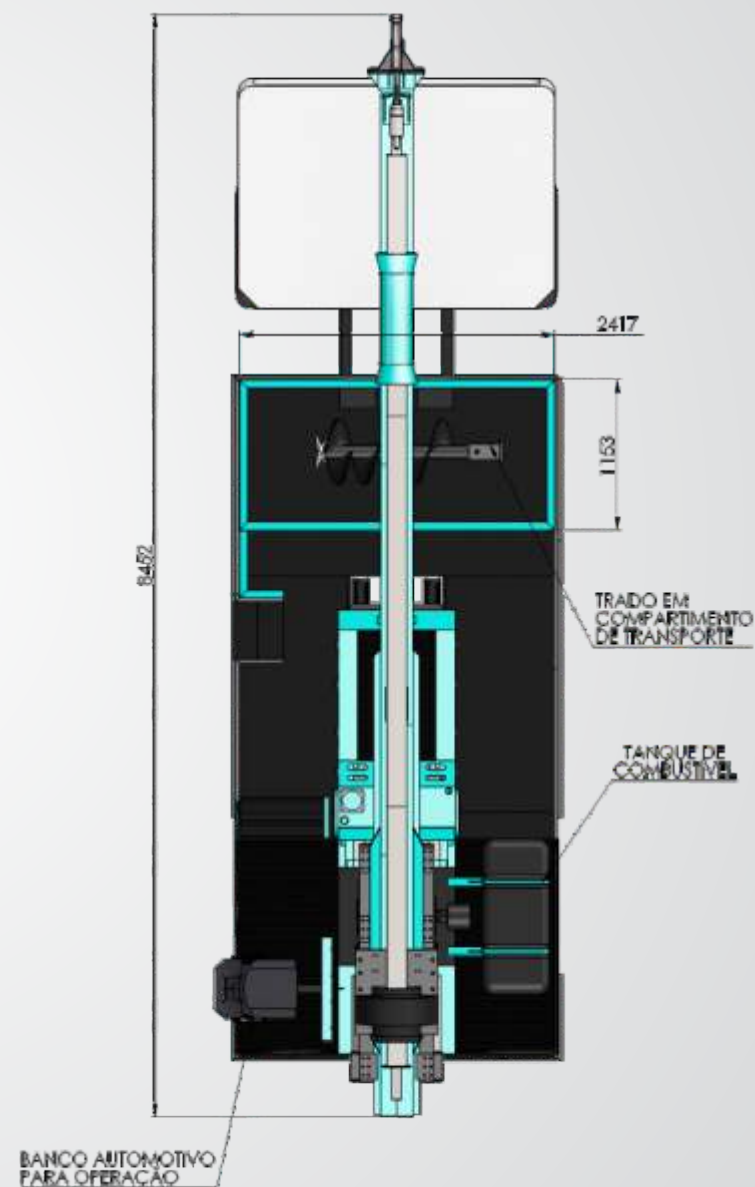
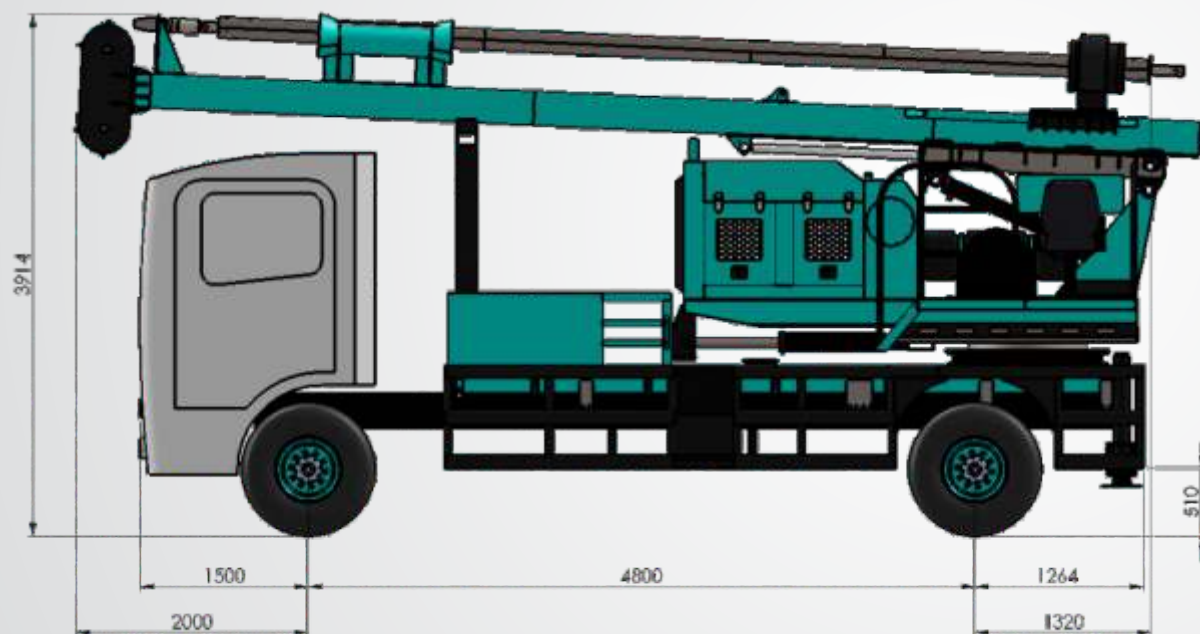



EVOMAQ[®]
EQUIPAMENTOS

MOGI MIRIM/SP
TEL.: (+55) 19 3806.1478 | 19 97158.9961
E-MAIL: VENDAS@EVOMAQ.COM.BR

WWW.EVOMAQ.COM.BR



CONHEÇA TAMBÉM NOSSA LINHA DE BOMBAS DE CONCRETO



AUTO BOMBA
DE CONCRETO
EVOMAQ[®]



BT BOMBA DE
CONCRETO
EVOMAQ[®]



BOMBA DE
CONCRETO
SOBRE ESTEIRA
EVOMAQ[®]



BOMBA DE CONCRETO
ESTACIONÁRIA
EVOMAQ[®]